



Chamber Mounting Flange

**Description**

A chamber mounting flange is offered to mount the vacuum chamber, the bench and the pumps together. This consists of an upper flange to fit the work chamber, a lower flange to mount the pumps, a bench mounting ring and two DN40CF accessory ports.

Optionally the chamber mounting flange can be extended to include a built in TSP housing with liquid nitrogen cooling.

**Features**

- Custom versions available on request

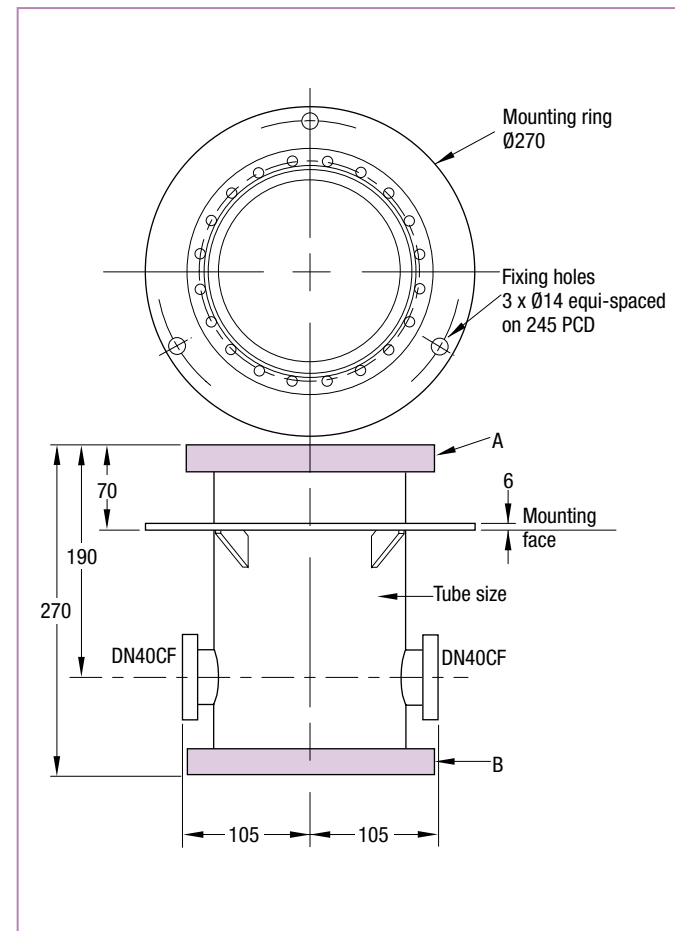

A TOP PORT	B PUMP PORT	ACCESSORY PORTS	TUBE OD	TUBE WALL THICKNESS	WT kg	REFERENCE	PART NUMBER	PRICE £	PRICE €	PRICE SFr
DN100CF	DN100CF	2 x DN40CF	108	2	9	VBF-100CF	1750100			Please Call
DN160CF	DN160CF	2 x DN40CF	156	3	10	VBF-160CF	1750101			Please Call
DN160CF	DN200CF	2 x DN40CF	156	3	11	VBF-200CF	1750102			Please Call
DN160CF	DN250CF	2 x DN40CF	156	3	12	VBF-250CF	1750103			Please Call

All dimensions are nominal in millimetres unless specified - Weights given are approximate

Contact your sales office for more details...



Vacuum Benches

**Description**

Caburn vacuum benches provide the essential component of a self-build system. Constructed from mild steel, the vacuum bench has a hole cut out for the positioning of a chamber mounting flange to connect the chamber above and hang pumps from below. The bench extension has a similar hole arrangement provided for the attachment of our bakeout fan units and one of our range of fast entry load-lock systems. Once chamber and fast entry load-lock have been positioned, with pumps and accessories attached, the whole assembly can be shrouded with a custom bakeout tent for UHV system bakeout.

**Features**

- Mild steel construction (stainless steel option)
- Painted with high temperature (250°C) grey paint
- Castor wheels to facilitate easy positioning
- Locking jacks for permanent mounting
- Cut-out holes for attachment of bakeout fan unit
- Optional bench extension
- Custom versions available on request

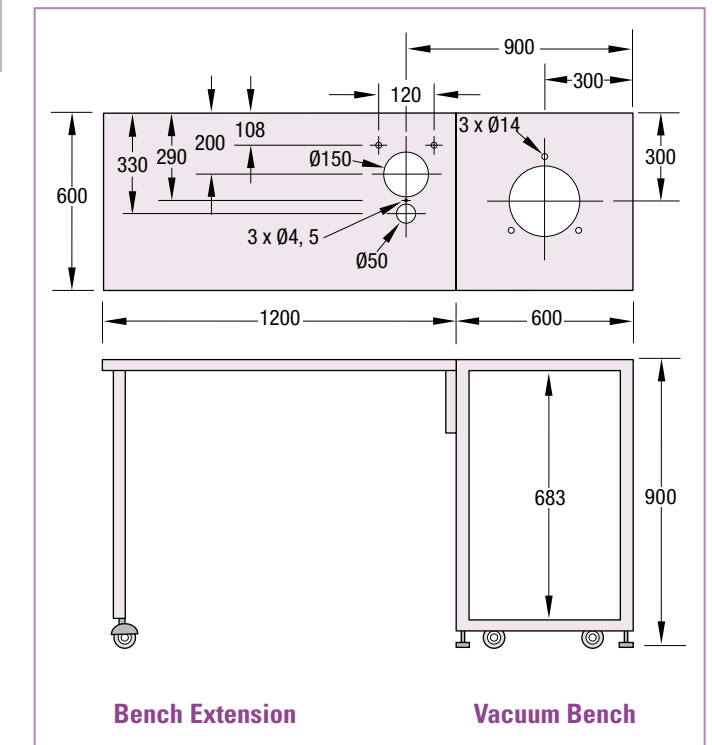

DESCRIPTION	WT kg	REFERENCE	PART NUMBER	PRICE £	PRICE €	PRICE SFr
MILD STEEL VACUUM BENCH	55	VB-MS	1750000			Please Call
BENCH EXTENSION	52	VBX	1750001			Please Call

All dimensions are nominal in millimetres unless specified - Weights given are approximate

Contact your sales office for more details...

