



Section 5.1 Viewports

Introduction



Features

- Full range of window materials
- Choice of flange mounting
- Non-magnetic models available
- Variety of glass-to-metal seals

Caburn-MDC viewports are offered mounted on CF, ISO KF and LF flanges.

Standard series use 7056 glass the most commonly used window material. Sealed to a Kovar® ring, the configuration is magnetic.

Non-magnetic assemblies are also offered with 316LN flanges.

An alternative material with a greater range of transmission, magnesium fluoride is also available.

Quartz, sapphire, magnesium fluoride and Pyrex® viewports are other options. Internal viewport shutters on page 236 protect windows from evaporated materials and radiated heat.

We are pleased to offer the unique range of VacOptix® viewports. Hermetically sealed optical components with expanded transmission in all spectral regions including ultraviolet, visible and infrared.

Viewports and glass components

Surface finish of viewports

The quality of polished viewport surfaces is often defined via the scratch-dig numbers, for example 80-50. The first digit defines the scratches, the second the digs.

Scratches

The scratch number defines the maximum width of a scratch in $\frac{1}{10}$ of a μm . So 80 corresponds to a maximum scratch width of $8\mu\text{m}$. The scratch width is determined by visual comparison.

The combined length of the maximum size scratches on each surface of a window is not allowed to exceed one quarter of the diameter of that window.

Digs

The dig number gives the maximum point defect size in $\frac{1}{100}\text{mm}$. A dig of 50 corresponds with $500\mu\text{m}$. All digs greater than $100\mu\text{m}$ must be separated by at least 1mm. For a window diameter of 20 to 40mm, only two maximum digs are allowed. The sum of all dig diameters must not exceed 4 times the maximum dig diameter.

Caburn-MDC offers as a standard finish of 80-20 scratch-dig. 20-10 is available on request for additional cost, which is normally required for service below $250\mu\text{m}$.

Viewports and glass components

Suggested cleaning procedure for optics

Step 1

Blow away all dust and debris from the optical surface with an air bulb. Avoid using shop air lines because they usually contain significant amounts of oil and water. These contaminants can be detrimental on optical surfaces.

Step 2

Dampen a cotton swab or cotton ball with acetone or propanol. Gently wipe the surface with the damp cotton. Do not rub hard. Use high quality, surgical cotton balls that have been sorted to remove any with embedded abrasives. Use only paper-bodied cotton swabs. Reagent grade acetone and propanol are recommended. Drag the cotton across the surface just fast enough so that the liquid evaporates right behind the cotton. This should leave no streaks.

Step 3

For severely contaminated and dirty parts, you may need to use an optical polishing compound to remove the absorbing layers from the optic. Carefully apply the polishing solution with a cotton ball (do not use swabs) or a special polishing pad. Use very light pressure and as few strokes as possible. Wipe with a clean cotton ball dampened with distilled water and then repeat step two. If you remove the thin film coating you will destroy the optic's performance. A change in the colour indicates the loss of a coating. Examine the part carefully.

General Information

Maximum bakeout temperatures are as shown. Viewports should be baked with care. They should be covered with aluminium foil. The maximum rate of temperature change should not exceed 3°C per minute.

A conductive coating may be applied to special order.

Special note

Only annealed gaskets should be used.



Section 5.1 Viewports

Standard series introduction



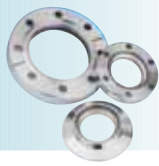

Section 5.1 Viewports

Standard series introduction

Viewports and glass components

Viewports and glass components

Section 5.1 Viewports and glass components

Standard series



Optical transmission curve glass

1mm thick reflection losses included

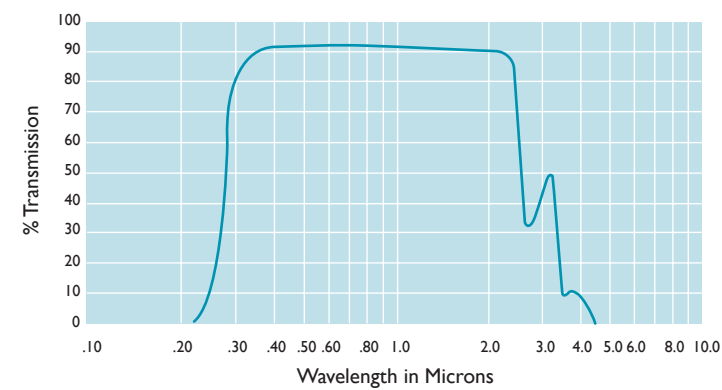

Please note that the optical transmission curves are approximations and should be used for reference only

Features

- Versatile general purpose viewports for high vacuum and UHV
- Wide transmission range
- Bakeable to 400°C with good resistance to thermal shocks
- Wide variety of accessories available including lead glass shields and viewport shutters
- Non-magnetic option with 316LN flanges on request
- Magnesium fluoride option available

Viewport selection table and specifications

Type of viewport	Maximum bakeout temperature of flange	Maximum bakeout temperature KF / LF flange	Window	Sleeve
304ss / 7056 glass	400°C	150°C	7056 Glass (kodial)	Kovar®
Non-magnetic 316LN	400°C	–	7056 Glass (kodial)	304ss
Magnesium fluoride	250°C	150°C	MgF ₂	304ss

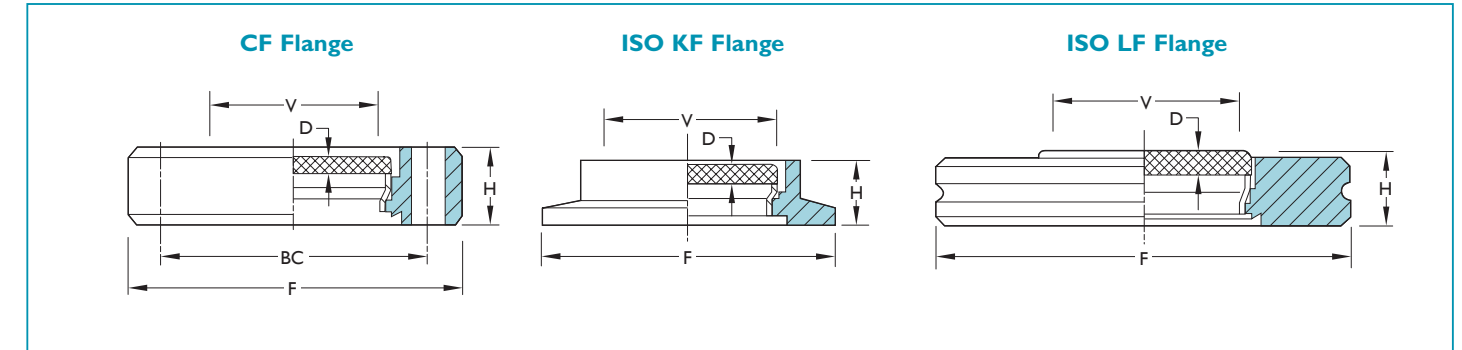

View diameter V	Flange	OD F	H	Glass thickness D	Wt kg	Reference	Part number	£	€	SFr.
304 Stainless steel / Kovar® sleeve										
16	DNI6CF	34	12.0	1.5	0.06	CVP-16	I210000	48	72	113
38	DN40CF	70	13.0	3.0	0.2	CVP-40	I210001	48	72	113
65	DN63CF	114	17.5	3.5	0.8	CVP-63	I210002	82	123	193
90	DNI00CF	152	20.0	6.0	1.5	CVP-100	I210003	190	285	447
135	DNI60CF	202	22.5	8.0	2.5	CVP-160	I210004	326	489	766
135	DN200CF	253	24.6	8.0	6.1	CVP-200	I210005	432	648	1015
15	DNI6KF	30	15	1.8	0.02	KVP-16	I210050	58	87	136
20	DN25KF	40	19	1.8	0.05	KVP-25	I210051	66	99	155
37	DN40KF	55	17.8	2.0	0.1	KVP-40	I210052	66	99	155
37	DN50KF	75	15	2.0	0.2	KVP-50	I210053	68	102	160
50	DN63LF	95	11.9	2.7	0.4	LVP-63	I210070	88	132	207
65	DNI00LF	130	17.5	4.3	0.8	LVP-100	I210071	114	171	268
98	DNI60LF	180	20.1	5.1	1.5	LVP-160	I210072	252	378	592

Non-magnetic viewports

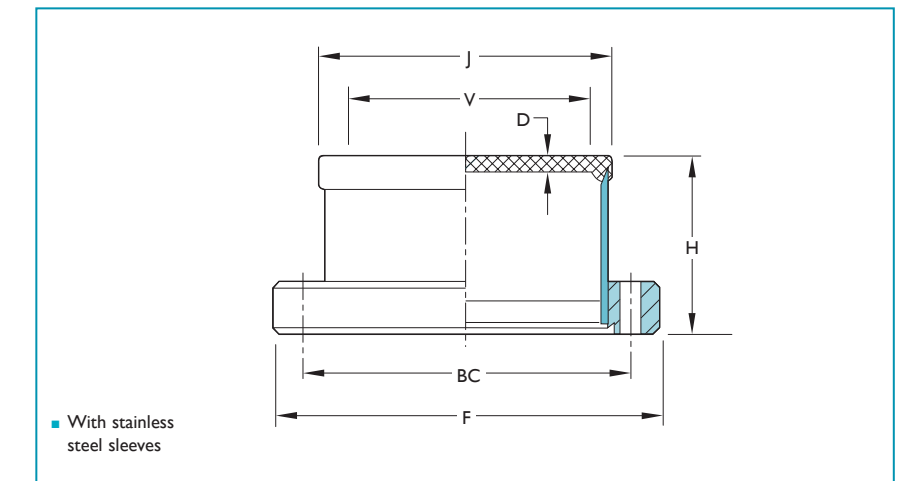

Features

- Non-magnetic housekeeper seal
- Wide transmission 7056 glass (kodial)

View diameter V	Flange	OD F	H	J	Glass thickness D	Wt kg	Reference	Part number	£	€	SFr.
316LN Stainless steel / 304 Stainless steel sleeve											
12.7	DNI6CF	34	28.4	–	1.8	0.3	CVP-16N	I210100	266	399	625
31.8	DN40CF	70	50.8	41.7	3.2	0.5	CVP-40N	I210101	356	534	837
50.8	DN63CF	114	53.8	–	4.3	1.1	CVP-63N	I210102	395	592	928
88.9	DNI00CF	152	53.8	–	5.1	1.6	CVP-100N	I210103	691	1037	1624
136.7	DNI60CF	202	69.9	–	9.5	3.0	CVP-160N	I210104	996	1494	2341

All dimensions are nominal in millimetres unless specified

Caburn-MDC Europe Limited Telephone +44 (0)870 428 7646 www.caburn.co.uk



All dimensions are nominal in millimetres unless specified Weights given are approximate

Caburn-MDC Europe Limited Telephone +44 (0)870 428 7646 www.caburn.co.uk

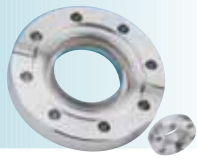

Transmission v wavelength

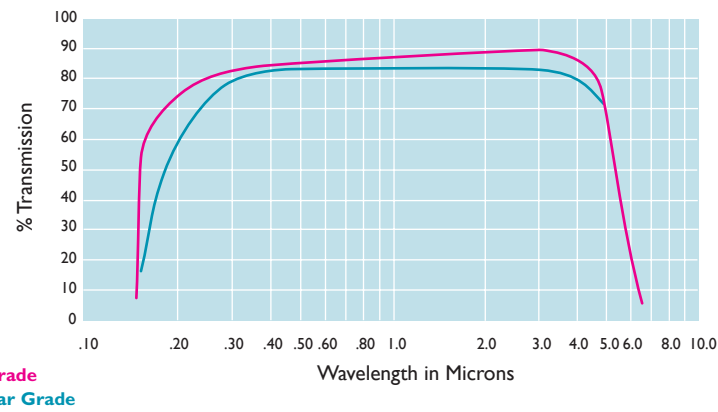

General specifications

Transmission range¹

Regular grade	0.30 to 4.00µm
UV Grade	0.2 to 4.50µm

Temperature rating²

CF Flange mount	to 450°C
ISO KF Flange mount	to 150°C

¹ Transmission curves are approximations, intended for reference only, they are based on a 1mm sample thickness as tested by sapphire manufacturers

² Thermal gradient should not exceed 25°C/minute

Sapphire

This is a synthetic, hexagonal single crystal anisotropic material which displays substantially different physical, thermal, dielectric and optical characteristics when measured along different axes. Caburn-MDC standard sapphire viewports use material with 90° crystal orientation, i.e. crystal orientation parallel to window surface. Viewports with crystal orientation parallel to optical axis, or 0° orientation, are available on request at additional cost. Most material grades are available up to 49mm.

Grades

All viewports up to 25mm in diameter are offered with UV grade sapphire; those exceeding 25mm diameters are offered with regular grade materials. UV grade material is available on request at additional cost.

Note Limitations in today's crystal growth technology make it difficult to guarantee constant transmission performance at wavelengths below 0.25 microns.

Surface finish

Poor surface finish can contribute as much as 10% to overall transmission losses. All viewports are supplied with flat faces which have been finished to standards suitable for most applications. Caburn-MDC's standard finish is a 50-20 scratch-dig. Other finishes are available on request at additional cost. The optics industry typically recommends a 20-10 scratch-dig optical finish for service below 0.25µm.

Crystal orientation

Crystal orientation of Caburn-MDC sapphire viewports is normal to optical axis or 90° orientation. Assemblies with crystal orientation parallel to optical axis or 0° orientation, are available on request at additional cost.

Features

- Sapphire single crystal
- 90° crystal orientation
- 50-20 Scratch-dig

Viewport coatings

Special order anti-reflection coatings can be applied to windows with view diameters greater than or equal to 25.4mm. Note that one window surface is recessed within the viewport's tubular metal mount which will produce shadowing on that side of the window. Caburn-MDC guarantees uniform AR coating over 80% of the window's clear aperture or view diameter. High temperature braze cycles (800°C) require that all coatings be applied after brazing.

Single layer Narrow band Anti-reflection SLAR

SLAR coating is available for sapphire or quartz window substrates. This coating may be tailored and optimized for specific wavelengths between 200nm and 2200nm, with reflection losses less than or equal to 0.5% per surface for either substrate material.

Multi-layer Broad band Anti-reflection MLAR

MLAR coating is available for sapphire or quartz window substrates. This coating is optimized for transmission over the entire range of wavelengths from 450nm to 800nm, with reflective losses at less than or equal to 1.0% per surface for either substrate material.

CF Flanges

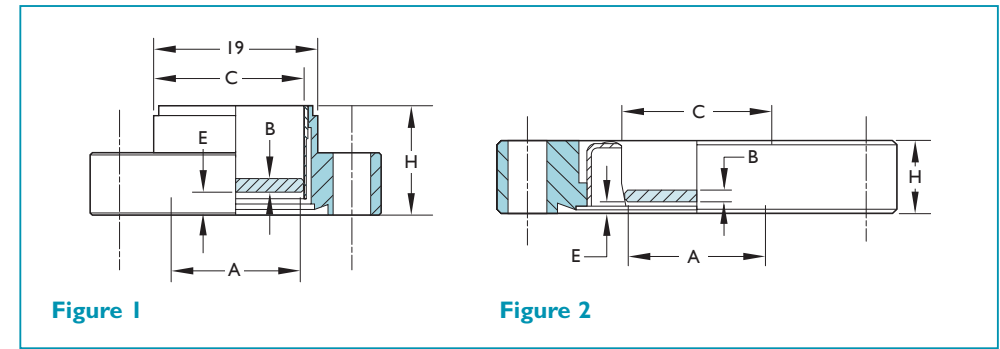
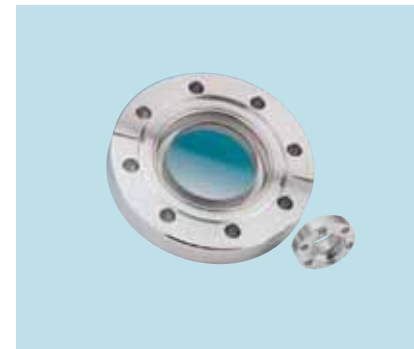

Grade	Flange	Nominal size	Figure	View diameter A	B	C	E	H	Wt kg	Reference	Part number	£	€	SFr.
UV	DNI16CF	9	2	8.9	2.0	9.6	1.6	7.2	0.04	VP-046S	9712007	181	311	468
UV	DNI16CF	15	1	14.9	2.7	16.0	1.6	12.7	0.04	VP-075S	9712000	189	326	490
UV	DN40CF	18	2	17.5	2.03	19.6	2.0	12.7	0.3	VP-069S	9712001	232	396	598
UV	DN40CF	24	2	23.8	2.03	25.9	2.0	12.7	0.3	VP-100S	9712002	232	396	598
Reg	DN40CF	37	2	36.6	2.39	38.6	2.5	12.7	0.3	VP-144S	9712005	537	992	1491
Reg	DN63CF	50	2	49.3	2.39	51.3	2.5	17.3	1.1	VP-200S	9712004	737	1267	1904

KF Flanges

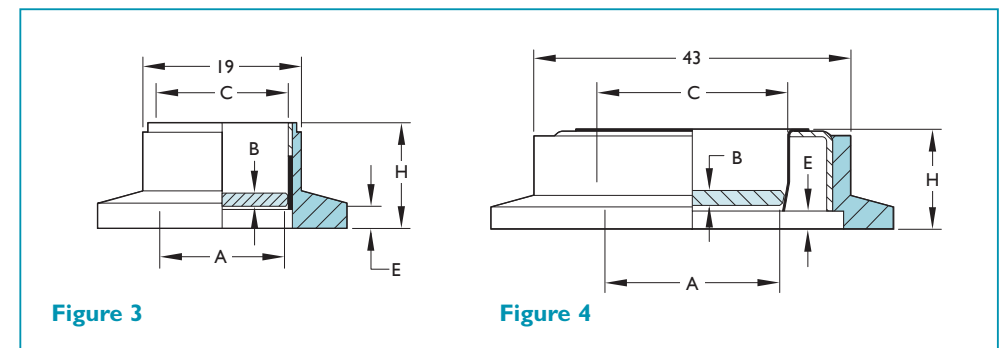
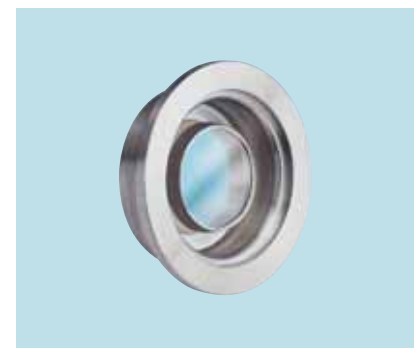

Grade	Flange	Nominal size	Figure	View diameter A	B	C	E	H	Wt kg	Reference	Part number	£	€	SFr.
UV	DNI16KF	15	3	15.0	1.57	16.0	3.3	12.7	0.1	KVP-075S	9713000	177	304	457
UV	DN40KF	18	4	17.5	2.03	19.6	3.3	12.7	0.2	KVP-150S	9713001	215	396	555
UV	DN40KF	24	4	23.9	2.03	25.9	3.3	12.7	0.2	KVP-150-1S	9713002	215	396	555

All dimensions are nominal in millimetres unless specified



All dimensions are nominal in millimetres unless specified Weights given are approximate

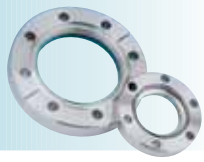

Section 5.1 Viewports

Fused silica introduction

Viewports and glass components

Viewports and glass components

Section 5.1 Viewports

Fused silica

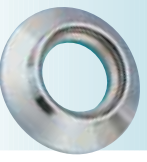

Transmission v wavelength

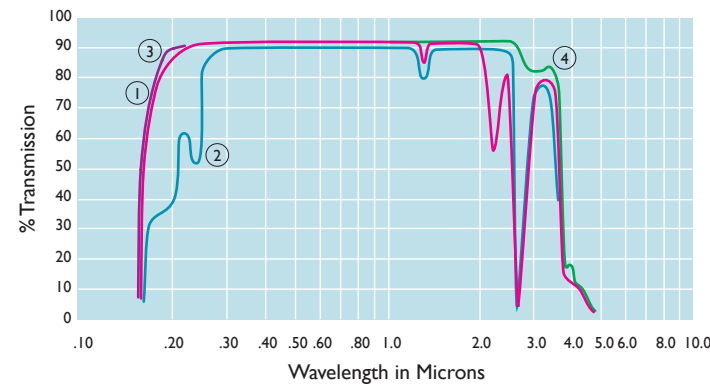

1 UV grade
2 Regular grade
3 Excimer UV
4 Infrared

General specifications

Transmission range¹

Fused quartz	Discontinued	0.30 to 2.50µm
Base ultraviolet	UV	0.20 to 2.00µm
Deep ultraviolet	DUV-200	0.20 to 2.00µm
Excimer ultraviolet	EUV-185	0.185 to 2.20µm
Infra-red, low OH	On request	0.185 to 2.20µm

Material	Inclusion class number	Total inclusion cross-section	Maximum inclusion cross-section	Index homogeneity grade	ppm
UV	2	0.10-0.25mm ²	0.50mm	F	≤5
DUV-200	0	0.00-0.03mm ²	0.10mm	A	≤1
EUV-185	0	0.00-0.03mm ²	0.10mm	C	≤2
Infrared	0	0.00-0.03mm ²	0.20mm	A	≤5

Temperature rating²

CF Flange mount	200°C ³
ISO KF Flange mount	150°C

¹ Transmission curves are approximations, intended for reference only, they are based on a 10mm sample thickness as tested by quartz manufacturers

² Thermal gradient should not exceed 25°C/minute

³ Lead-silver braze alloy melts at 305°C

Description

Caburn-MDC fused silica viewports are designed and rated for high and ultra-high vacuum applications. They are constructed using vacuum grade materials including high purity silicon dioxide, 304 stainless steel and vacuum tube-grade braze alloys.

Fused silica is a polycrystalline, isotropic material with no crystal orientation. Its physical, thermal, dielectric and optical properties are uniform in all directions of measurement.

Conventional fused quartz is suitable for basic non-demanding optical applications. Impurities in fused quartz cause a blue-violet fluorescence when exposed to ultraviolet radiation at 253.7µm. This fluorescence is not evident in synthetic fused silica, which is manufactured by flame hydrolysis of silicon tetrachloride.

Caburn-MDC offers three ultraviolet grades of fused silica. A base ultraviolet and two deep ultraviolet grades, DUV-200 and EUV-185.

Features

- Synthetic fused silica
- Standard and zero length
- 40-20 scratch-dig
- Non-coated optics
- Six sizes available

The base UV grade material is suitable for all but the most demanding optical applications and certified to meet ≥80%/cm @185nm external transmittance. DUV-200 fused silica is equivalent to Suprasil-I® and similar to the base grade with the exception of inclusion specifications. EUV-185 is an excimer grade window material which offers excellent performance for excimer-UV laser applications. This material is certified to meet ≥85%/cm @185nm external transmittance.

Infrared fused silica windows with low 'OH' content can be quoted for applications requiring IR transmission to about 3600nm. This material has less than 1ppm OH content which eliminates the typical absorption band found in other materials.

Fused silica viewports are preferred over glass viewports because of their transparency to ultraviolet radiation. Other advantages include a higher abrasion resistance and a low coefficient of thermal expansion, making them very resistant to thermal shock. Poor surface finish can contribute as much as 10% overall transmission losses. All viewports are supplied with flat faces which have been finished to standards suitable for most applications. Caburn-MDC standard finish for fused silica viewports is 40-20 scratch-dig. Other finishes are available on request at additional cost. For Deep-UV grade materials, the optics industry typically recommends a 20-10 scratch-dig optical finish for service below 0.25 microns.

CF Flanges

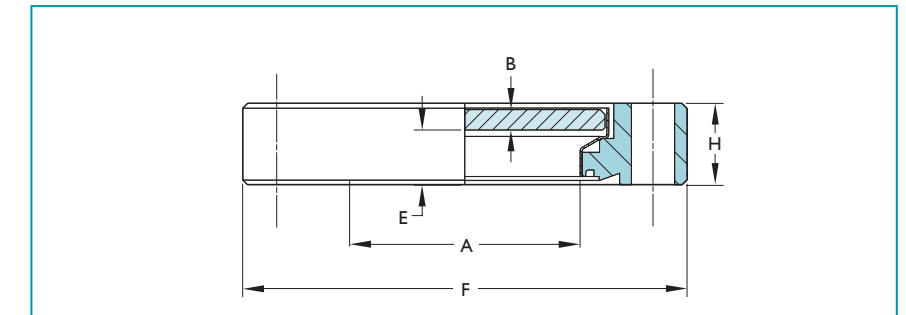

Zero length fused silica viewports Ultraviolet

Window material	CF flange	Nominal size	View dia. A	B	E	F	H	Wt kg	Reference	Part number	£	€	SFr.
Fused silica	DN16CF	20	16.0	2.5	4.3	34	7.4	0.3	VP-UV-C16	9722013-I	164	282	424
Fused silica	DN40CF	38	35.6	3.3	8.9	70	12.7	0.4	VP-UV-C40	9722005-I	168	289	435
Fused silica	DN63CF	63	68.3	6.4	10.4	114	17.3	1.1	VP-UV-C63	9722007-I	547	941	1415
Fused silica	DN100CF	102	98.6	6.4	13.0	152	19.8	1.4	VP-UV-C100	9722009-I	674	1158	1741
Fused silica	DN160CF	152	136.7	9.7	12.2	203	22.4	1.6	VP-UV-C160	9722011-I	2000	3439	5168
Fused silica	DN200CF	203	197.6	9.7	13.5	254	24.6	2.7	VP-UV-C200	9722012-I	2589	4454	6692

Zero length fused silica viewports Deep ultraviolet

Window material	CF flange	Nominal size	View dia. A	B	E	F	H	Wt kg	Reference	Part number	£	€	SFr.
Fused silica	DN16CF	16	16.0	2.5	4.3	34	7.4	0.3	VP-DUV-200-C16	9722213	257	442	664
Fused silica	DN40CF	38	35.6	3.3	8.9	70	12.7	0.4	VP-DUV-200-C40	9722205	295	506	762
Fused silica	DN63CF	63	68.3	6.4	10.4	114	17.3	1.1	VP-DUV-200-C63	9722207	947	1629	2448
Fused silica	DN100CF	102	98.6	6.4	13.0	152	19.8	1.4	VP-DUV-200-C100	9722209	1672	2875	4320

Zero length fused silica viewports Excimer ultraviolet

Window material	CF flange	Nominal size	View dia. A	B	E	F	H	Wt kg	Reference	Part number	£	€	SFr.
Fused silica	DN16CF	16	16.0	2.5	4.3	34	7.4	0.3	UV-EUV-185-C16	9722300	379	652	979
Fused silica	DN40CF	38	35.6	3.3	8.9	70	12.7	0.4	UV-EUV-185-C40	9722301	779	1340	2013
Fused silica	DN63CF	63	68.3	6.4	10.4	114	17.3	1.1	UV-EUV-185-C63	9722302	2105	3620	5441

KF Flanges

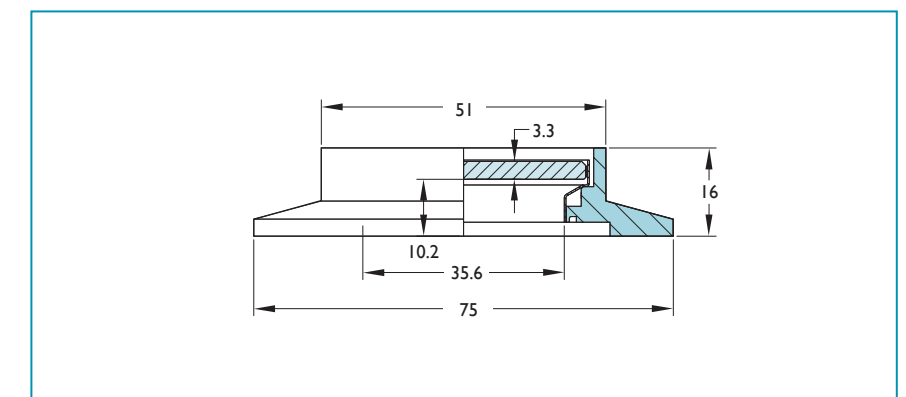

Zero length fused silica viewports Ultraviolet

Window material	Nominal size	View dia. A	Wt kg	Reference	Part number	£	€	SFr.
DN50KF	38	35.6	0.2	KVP-150Q	9723002	191	296	446

All dimensions are nominal in millimetres unless specified

Caburn-MDC Europe Limited Telephone +44 (0)870 428 7646 www.caburn.co.uk



All dimensions are nominal in millimetres unless specified Weights given are approximate

Caburn-MDC Europe Limited Telephone +44 (0)870 428 7646 www.caburn.co.uk

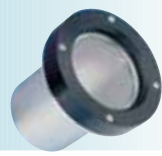

Section 5.1
Viewports
Weldable Pyrex®

Viewports and glass components

Viewports and glass components

Section 5.1
Viewports
Magnesium Fluoride

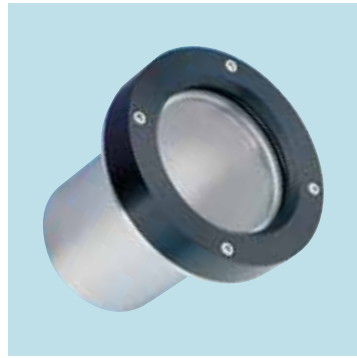

Features

- Weld neck, 101.6mm OD
- Pyrex® 7740 borosilicate optical glass
- 100mm diameter nominal viewing area
- Type 304 stainless steel mounting
- Viton® O-ring seal
- Replaceable glass

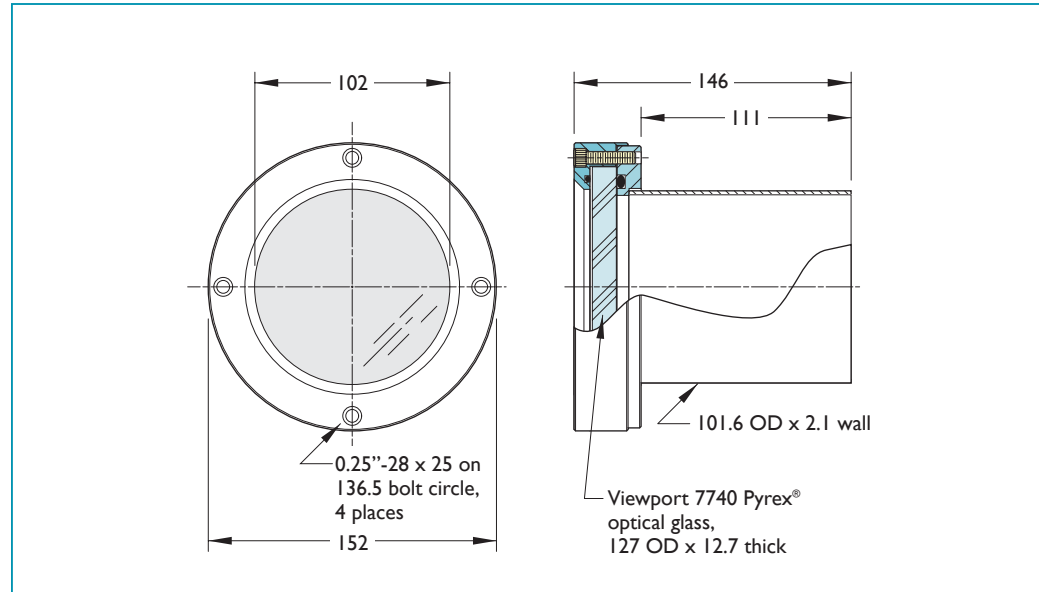

Description

Economical visual quality viewport used on high vacuum chambers. Weldable configuration allows installation on a custom built stainless steel chamber. The replaceable viewport glass is captured between two elastomer O-rings. The viewport can be easily disassembled by removing four screws from the retainer ring.

Description	Wt kg	Reference	Part number	£	€	SFr.
Pyrex viewport with 102mm OD weld neck	1.5	PVP-4	450010	316	474	816

Spare parts

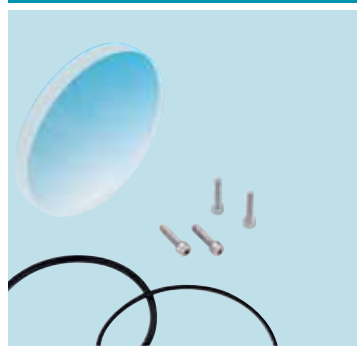

Description	Wt kg	Reference	Part number	£	€	SFr.
Replacement glass, 7740 pyrex optical 127mm OD	0.5	PRG-4	045010	126	189	352
Bolt, socket head, ss 0.25\"-28 x 1\" long (pack of 4)	0.1	BSPW	190166	3	5	11
O-ring, glass-to-flange	0.1	VO-2-346	041346	7	11	20
O-ring, glass-to-retainer	0.1	VO-2-243	041243	8	13	37

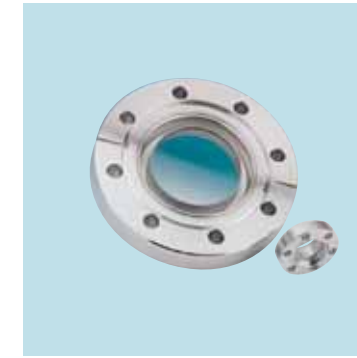

Features

- UHV compatible
- Bakeable to 300°C
- Wider transmission range than the standard series

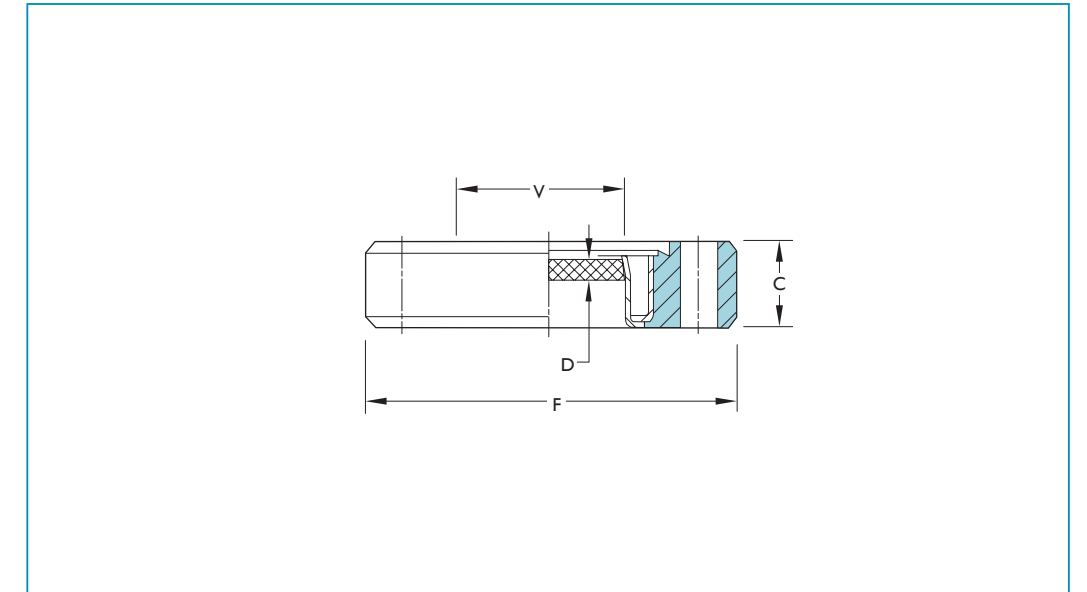

Transmission v wavelength

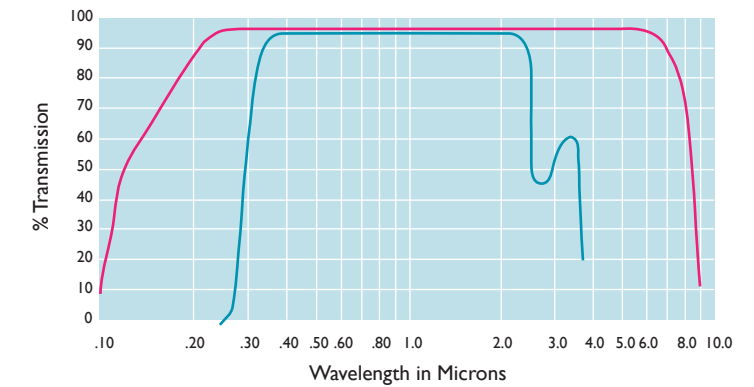

Magnesium fluoride
7056

View diameter V	Flange	OD F	Flange thickness C	Magnesium fluoride thickness D	Reference	Part number	£	€	SFr.
20	DN40CF	70	12.7	2	CVPMG22	1210200	357	534	839
38	DN40CF	70	12.7	3	CVPMG40	1210201	817	1251	1912

All dimensions are nominal in millimetres unless specified. Weights given are approximate.



All dimensions are nominal in millimetres unless specified.

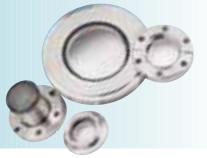

Unique VacOptix® hermetic seal design

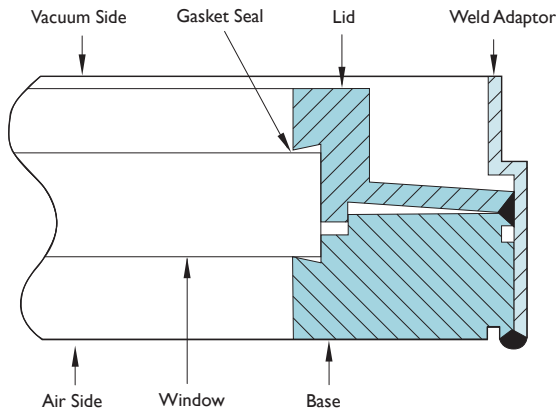

Features

- Extended UV-IR range materials
- Optional AR coatings
- VacOptix® sealed optics

Calcium fluoride

Cleartran

Magnesium fluoride

Zinc selenide

VacOptix® is a breakthrough in hermetic seal technology. It is a patented method for making optical assemblies with virtually any glass or crystalline material. This new technique, VacOptix®, allows Caburn-MDC to offer a wider range of hermetically sealed optical components with expanded transmission in all spectral regions including ultraviolet, visible and infrared.

VacOptix® seal technology has been developed for service in such demanding environments as corrosive chemical, cryogenic and ultra-high vacuum. Only non-magnetic, low vapour pressure materials such as 304 stainless steel hardware and aluminum gaskets are employed to seal all available window materials.

Plane parallel windows are offered without anti-reflective coatings. Plano convex, plano concave and anti-reflective coatings are available on request at additional cost.

For special optical, chemical, pressure, cryogenic or vacuum needs please call technical sales. VacOptix®, hermetic seal technology designs are no longer constrained with the limitations of prior sealing techniques which are unable to produce reliable hermetic seals of such material diversity.

General specifications

Transmission range¹

See charts opposite

Temperature rating²

CF to 200°C

¹ Transmission charts are for reference only

² Thermal gradient should not exceed 10°C/minute

³ VacOptix® is a registered trademark of Insulator Seal – patent pending

Calcium fluoride (CaF₂)

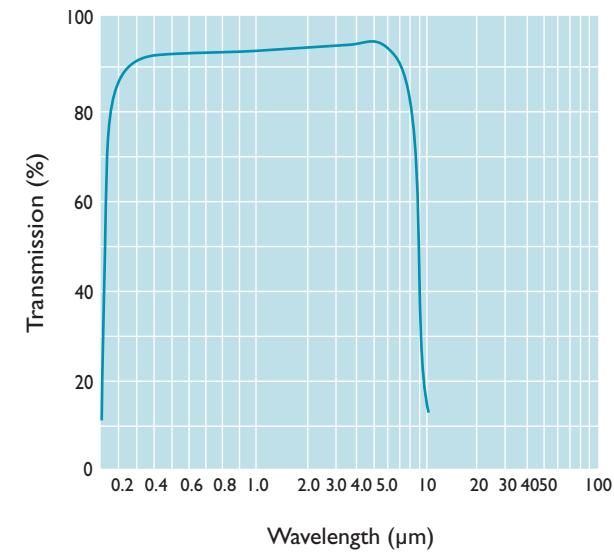

Cleartran™

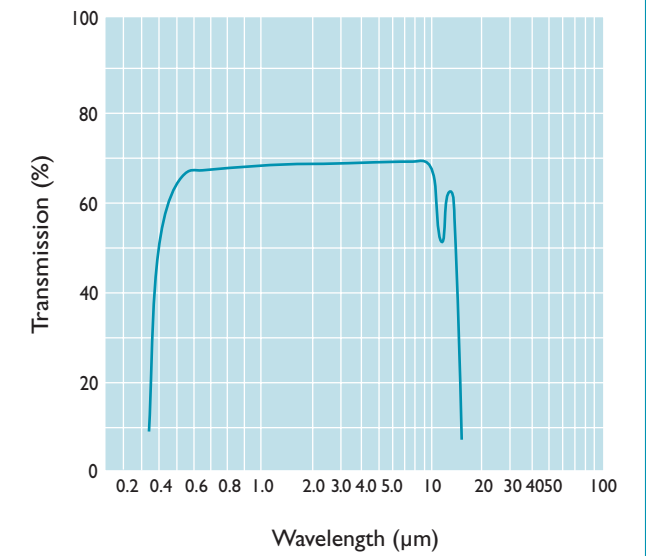

Magnesium fluoride (MF₂)

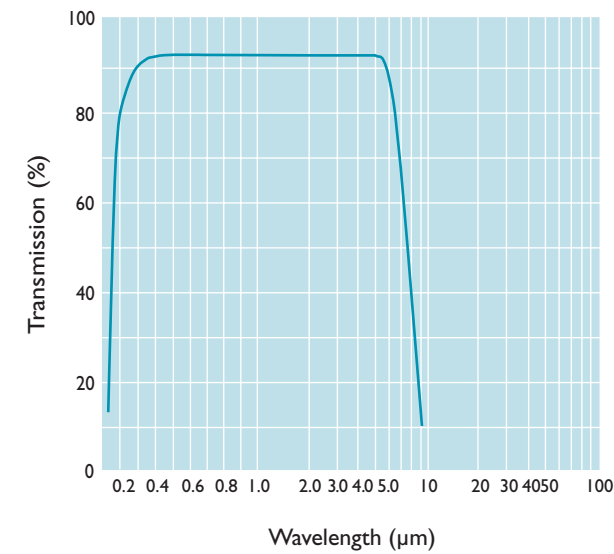

Zinc selenide (ZnSe)

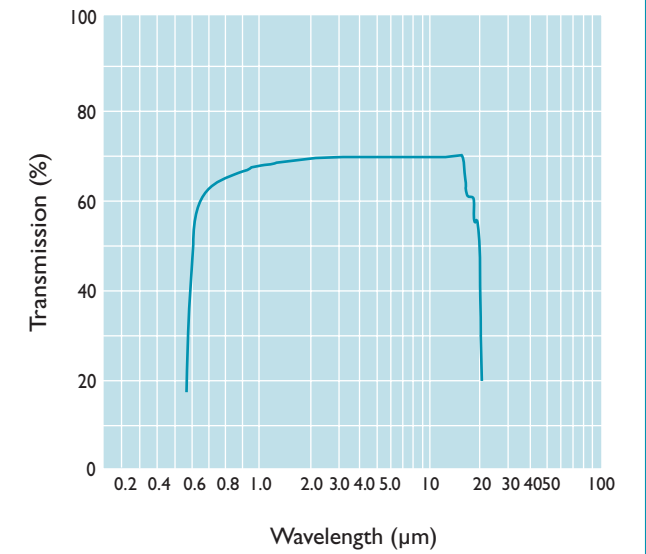

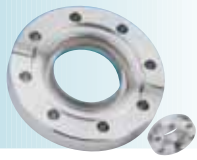

Section 5.1
Viewports

Standard VacOptix® viewports

Viewports and glass components

Viewports and glass components

Section 5.1
Viewports

Coated VacOptix® viewports

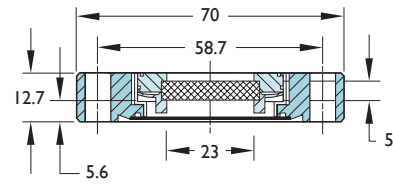
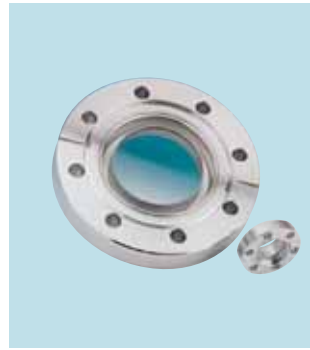
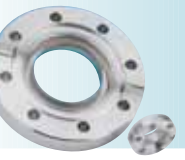

Figure 1

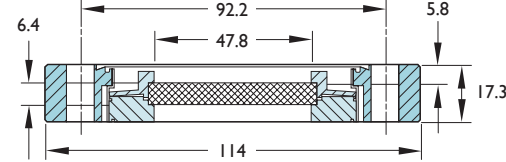

Figure 2

Material	Figure	Flange	Wt kg	Reference	Part number	£	€	SFr.
Magnesium fluoride	1	DN40CF	0.7	VOMF-C40	9792054	733	1260	1893
Magnesium fluoride	2	DN63CF	1.1	VO2MF-C63	9792056	918	1578	2372
Calcium fluoride	1	DN40CF	0.7	VOCF-C40	9792094	623	1072	1610
Calcium fluoride	2	DN63CF	1.1	VO2CF-C63	9792096	699	1202	POA
Cleartran	1	DN40CF	0.7	VOCL-C40	9792724	POA	POA	POA
Cleartran	2	DN63CF	1.1	VO2CL-C63	9792726	POA	POA	POA
Zinc selenide	1	DN40CF	0.7	VOZS-C40	9792884	POA	POA	POA
Zinc selenide	2	DN63CF	1.1	VO2ZS-C63	9792886	POA	POA	POA

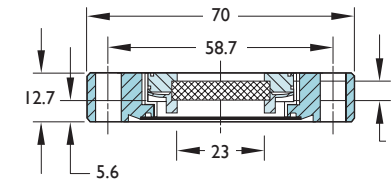
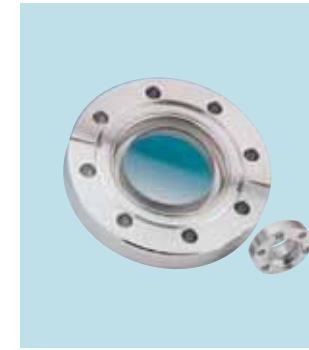

Figure 1

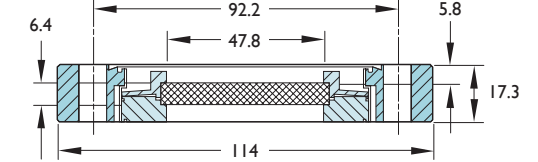

Figure 2

Material	Fig.	Flange	Coating	Wt kg	Reference	Part number	£	€	SFr.
Cleartran	1	DN40CF	8-12 µm	0.7	CVOCE12000-C40	9792731	POA	POA	POA
Cleartran	2	DN63CF	8-12 µm	1.1	CVO2CE12000-C63	9792733	POA	POA	POA
Cleartran	1	DN40CF	10.6 µm	0.7	CVOCE10600-C40	9792751	POA	POA	POA
Cleartran	2	DN63CF	10.6 µm	1.1	CVO2CE10600-C63	9792753	POA	POA	POA
Zinc selenide	1	DN40CF	8-12 µm	0.7	CVOZS12000-C40	9792891	POA	POA	POA
Zinc selenide	2	DN63CF	8-12 µm	1.1	CVO2ZS12000-C63	9792893	POA	POA	POA
Zinc selenide	1	DN40CF	10.6 µm	0.7	CVOZS10600-C40	9792901	POA	POA	POA
Zinc selenide	2	DN63CF	10.6 µm	1.1	CVO2ZS10600-C63	9792903	POA	POA	POA

All dimensions are nominal in millimetres unless specified. Weights given are approximate.



All dimensions are nominal in millimetres unless specified. Weights given are approximate.



Section 5.1 Viewports

Shutter accessories

Viewports and glass components

Viewports and glass components

Section 5.1 Viewports

Viewport shield accessories



UHV Series

Description

VPS Series rotary viewport shutters provide quick and efficient shielding for standard viewports. These shutters are ideally suited for service in high and ultrahigh vacuum coating applications. They are swing-type, pivoting shutters that are mounted between viewports and chamber port flanges. The shape of each shutter has been designed to maximize its aperture into a standard tubed port. The actual amount of shutter swing will be dependent on the mating chamber port's tube diameter.

The table below gives the maximum swing angle for shutters mounted on Caburn-MDC half-nipples fitted with standard CF metal seal flanges with corresponding tube diameters. To provide maximum shielding of viewports, each shutter body has a step machined to match the shape and contour of the shutter's flap. Actuation of the shutter is provided through a Caburn-MDC bellows sealed rotary drive. Improved design features include all stainless steel body allowing for bakeout up to 230°C. A positive click-stop action has also been added to the rotary driver that allows for partial opening of the shutter's flapper plate between the fully opened and fully closed positions. Shutter path must be unobstructed during actuation as shutter mechanism can be damaged when shutter is forced beyond a clear and unobstructed travel path, such as smaller tube diameters.

Features

- 100% viewport shielding
- Double-sided flange mount
- CF metal seal interface
- Actuated with bellows sealed rotary feedthrough
- All stainless steel construction
- Four flange sizes
- Bakeable to 200°C

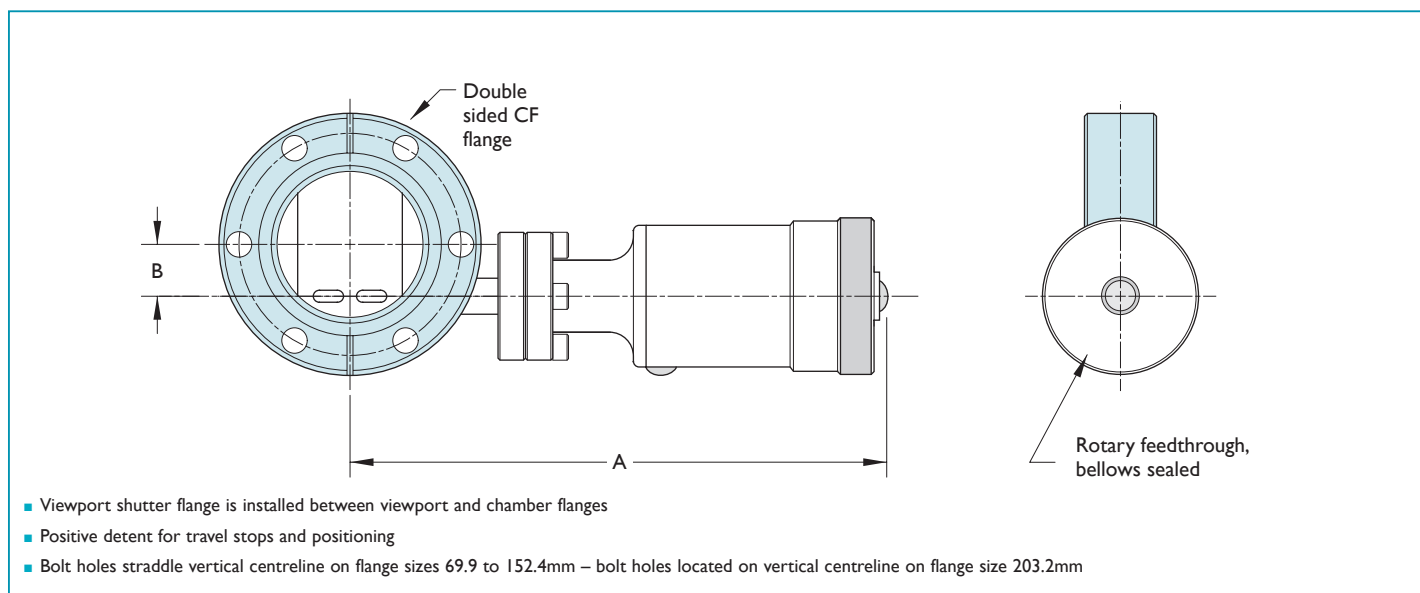

Nominal flange	Flange OD	Flange thickness	A	B	Shutter angle	Wt kg	Reference	Part number	£	€	SFr.
DN40CF	70	19	142	13.7	85°	0.7	VPS-275	454000	547	941	1415
DN63CF	114	17	180	27.2	72°	1.4	VPS-450	454001	695	1194	1795
DNI00CF	152	20	188	45.2	75°	2.0	VPS-600	454002	821	1412	2122
DNI60CF	203	22	207	63.2	78°	4.3	VPS-800	454003	947	1629	2448

Refer to individual double-sided flange size for mounting hardware

All dimensions are nominal in millimetres unless specified Weights given are approximate

Caburn-MDC Europe Limited Telephone +44 (0)870 428 7646 www.caburn.co.uk



Caburn-MDC Europe Limited Telephone +44 (0)870 428 7646 www.caburn.co.uk

All dimensions are nominal in millimetres unless specified

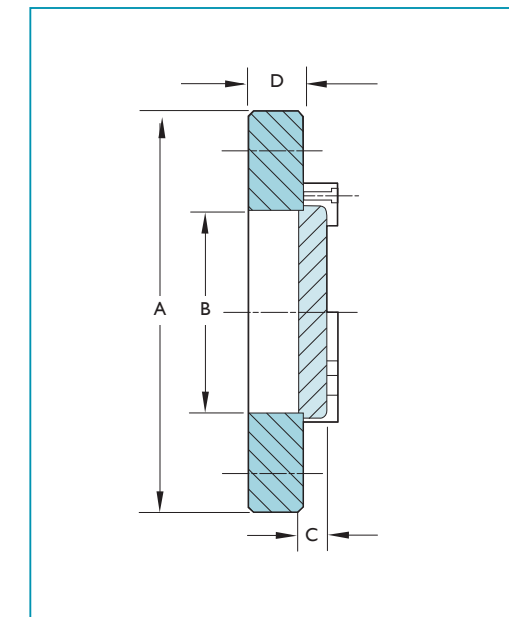

Features

- Lead equivalent see below
- For radiation protection
- RWB 46 glass contains 48% Pb and 15% Ba
- Easily mountable to viewports fitted with CF flanges
- Bakeable to 250°C
- Lead glass screens are not leak tight and must be used in conjunction with vacuum viewports
- Use bolt sets for double sided flanges [see corresponding flange size accessories](#)

Lead equivalent

6mm thickness	100-110KV	1.86mm
	150KV	1.80mm
	200KV	1.50mm

Port flange	OD A	View B	Glass thickness C	Shield thickness D	Wt kg	Reference	Part number	£	€	SFr.
DN40CF	70	39	6	10	0.5	LG-40	1210300	87	135	204
DN63CF	114	66	6	10	1.4	LG-63	1210301	165	257	386
DNI00CF	152	89	6	10	2.5	LG-100	1210302	255	397	597
DNI60CF	203	139	6	10	5.5	LG-160	1210303	360	561	842